

**Prepared For:**

Hickory Stock  
 Hickory Stock Unit  
 1704 Conowingo Rd.  
 Bel Air, MD 21014-  
 (410)838 - 4200

**Presented By:**

HICKORY INTERNATIONAL INC  
 ROBERT M PRESTON  
 1704 CONOWINGO RD  
 P.O. BOX 469  
 BEL AIR MD 21014 -  
 (410)838-4200

Thank you for the opportunity to provide you with the following quotation on a new International truck. I am sure the following detailed specification will meet your operational requirements, and I look forward to serving your business needs.

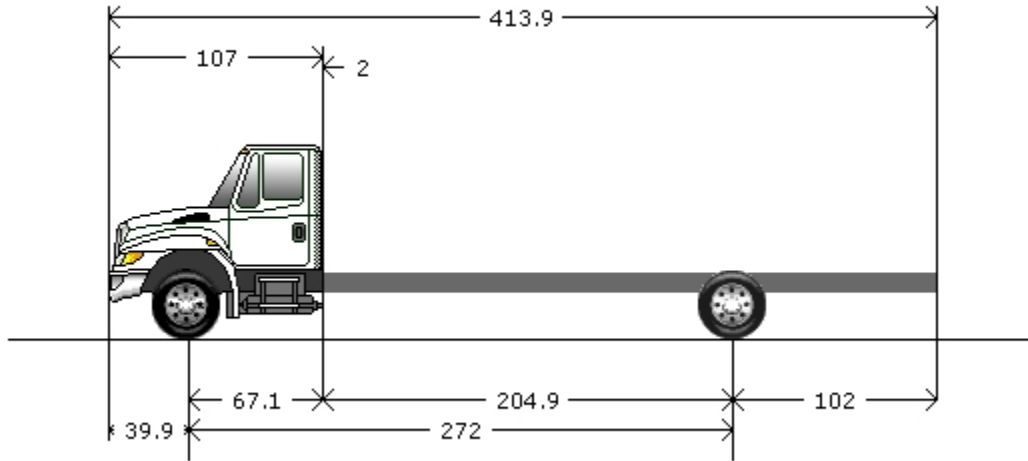

**Model Profile**  
**2017 4300 SBA 4X2 (MA025)**

<b>MISSION:</b>	Requested GVWR: 25999. Calc. GVWR: 25999
<b>DIMENSION:</b>	Calc. Start / Grade Ability: 33.13% / 2.45% @ 55 MPH
<b>ENGINE, DIESEL:</b>	Wheelbase: 272.00, CA: 204.90, Axle to Frame: 102.00 {Cummins ISB 300} EPA 2010, 300 HP @ 2600 RPM, 660 lb-ft Torque @ 1600 RPM, 2600 RPM Governed Speed, 300 Peak HP (Max)
<b>TRANSMISSION, AUTOMATIC:</b>	{Allison 2500_RDS_P} 5th Generation Controls; Wide Ratio, 6-Speed, with Double Overdrive; with PTO Provision, Less Retarder, with 33,000-lb GVW & GCW Max
<b>CLUTCH:</b>	Omit Item (Clutch & Control)
<b>AXLE, FRONT NON-DRIVING:</b>	{Navistar Select} I-Beam Type, 10,000-lb Capacity
<b>AXLE, REAR, SINGLE:</b>	{Navistar Select} Single Reduction, Hypoid Gearing, 19,000-lb Capacity, 190 Wheel Ends Gear Ratio: 5.57
<b>CAB:</b>	Conventional
<b>TIRE, FRONT:</b>	(2) 295/75R22.5 ECO PLUS HS3 (CONTINENTAL) 519 rev/mile, load range G, 14 ply
<b>TIRE, REAR:</b>	(4) 295/75R22.5 ECO PLUS HD3 (CONTINENTAL) 511 rev/mile, load range G, 14 ply
<b>SUSPENSION, RR, SPRING, SINGLE:</b>	Vari-Rate; 23,500-lb Capacity, With 4500 lb Auxiliary Rubber Spring
<b>PAINT:</b>	Cab schematic 100GA Location 1: 9219, Winter White (Std) Chassis schematic N/A

<u>Description</u>	<u>F/R Wt</u> (lbs)	<u>Tot Wt</u> (lbs)
Base Chassis, Model 4300 SBA 4X2 with 272.00 Wheelbase, 204.90 CA, and 102.00 Axle to Frame.	5567/2901	8468
TOW HOOK, FRONT (2) Frame Mounted	8/0	8
FRAME RAILS Heat Treated Alloy Steel (120,000 PSI Yield); 10.125" x 3.580" x 0.312" (257.2mm x 90.9mm x 8.0mm); 420.0" (10668mm) Maximum OAL	183/536	719
BUMPER, FRONT Full Width, Aerodynamic, Chrome Plated Steel; 0.142" Material Thickness	-1/0	-1
CROSSMEMBER, REAR, AF (1)	0/20	20
WHEELBASE RANGE 256" (650cm) Through and Including 311" (790cm)	0/0	0
AXLE, FRONT NON-DRIVING {Navistar Select} I-Beam Type, 10,000-lb Capacity	41/0	41
SUSPENSION, FRONT, SPRING Parabolic, Taper Leaf; 10,000-lb Capacity; With Shock Absorbers	66/0	66
<u>Includes</u>		
: SPRING PINS Rubber Bushings, Maintenance-Free		
<u>Notes</u>		
: The following features should be considered when calculating Front GAWR: Front Axles; Front Suspension; Brake System; Brakes, Front Air Cam; Wheels; Tires.		
BRAKE SYSTEM, AIR Dual System for Straight Truck Applications	107/23	130
<u>Includes</u>		
: BRAKE LINES Color and Size Coded Nylon		
: DRAIN VALVE Twist-Type		
: GAUGE, AIR PRESSURE (2) Air 1 and Air 2 Gauges; Located in Instrument Cluster		
: PARKING BRAKE CONTROL Yellow Knob, Located on Instrument Panel		
: PARKING BRAKE VALVE For Truck		
: QUICK RELEASE VALVE Bendix On Rear Axle for Spring Brake Release: 1 for 4x2, 2 for 6x4		
: SLACK ADJUSTERS, FRONT Automatic		
: SLACK ADJUSTERS, REAR Automatic		
: SPRING BRAKE MODULATOR VALVE R-7 for 4x2, SR-7 with relay valve for 6x4		
<u>Notes</u>		
: Front and Rear Dust Shields not Included		
: Rear Axle is Limited to 19,000-lb GAWR with Code 04091 BRAKE SYSTEM, AIR and Code 04NCL BRAKES, REAR, AIR CAM Regardless of Axle/Suspension Ordered.		
: Rear Axle is Limited to 20,000-lb GAWR with Code 04091 BRAKE SYSTEM, AIR and Code 04NCG BRAKES, REAR, AIR CAM Regardless of Axle/Suspension Ordered.		
: Rear Axle is Limited to 23,000-lb GAWR with Code 04091 BRAKE SYSTEM, AIR and Standard Rear Air Cam Brakes Regardless of Axle/Suspension Ordered.		
DRAIN VALVE {Berg} Manual; With Pull Chain, for Air Tank	1/0	1
<u>Includes</u>		
: DRAIN VALVE Mounted in Wet Tank		
AIR BRAKE ABS {Bendix AntiLock Brake System} Full Vehicle Wheel Control System (4-Channel) With Automatic Traction Control	4/1	5
AIR DRYER {Meritor Wabco System Saver 1200} with Heater	-19/31	12
<u>Includes</u>		
: AIR DRYER LOCATION Inside Left Rail, Back of Cab		
BRAKE CHAMBERS, FRONT AXLE {Bendix} 20 SqIn	17/0	17
BRAKE CHAMBERS, REAR AXLE {Bendix EverSure} 30/30 Spring Brake	0/0	0
BRAKES, FRONT, AIR CAM S-Cam; 15.0" x 4.0"; Includes 20 Sq. In. Long Stroke Brake Chambers	83/0	83

<u>Description</u>	<u>F/R Wt</u> (lbs)	<u>Tot Wt</u> (lbs)
<u>Notes</u>		
: Front Axle with 14,000-lb GAWR is Limited to 13,200-lb GAWR when used in Conjunction with 15" BRAKES, FRONT, AIR CAM.		
: The following features should be considered when calculating Front GAWR: Front Axles; Front Suspension; Brake System; Brakes, Front Air Cam; Wheels; Tires.		
BRAKES, REAR, AIR CAM S-Cam; 16.5" x 7.0"; Includes 30/30 Sq.In. Long Stroke Brake Chamber and Spring Actuated Parking Brake	0/211	211
<u>Notes</u>		
: The following features should be considered when calculating Front GAWR: Front Axles; Front Suspension; Brake System; Brakes, Front Air Cam; Wheels; Tires.		
AIR COMPRESSOR {Cummins} 18.7 CFM Capacity	36/0	36
STEERING COLUMN Tilting	0/0	0
STEERING WHEEL 2-Spoke, 18" Diam., Black	0/0	0
STEERING GEAR {Sheppard M-100} Power	25/0	25
EXHAUST SYSTEM Inline, Horizontal Aftertreatment Device Frame Mounted Right Side, Includes Short Horizontal Tail Pipe	0/0	0
ENGINE EXHAUST BRAKE for Cummins ISB/ISL Engine With Variable Geometry Turbo Charger	0/0	0
SWITCH, FOR EXHAUST 2 Position, Lighted & Latching, ON/OFF Type, Mounted in IP, Inhibits Diesel Particulate Filter Regeneration as Long as Switch is in ON Position	2/0	2
ELECTRICAL SYSTEM 12-Volt, Standard Equipment	0/0	0
<u>Includes</u>		
: BATTERY BOX Steel		
: DATA LINK CONNECTOR For Vehicle Programming and Diagnostics In Cab		
: FUSES, ELECTRICAL SAE Blade-Type		
: HAZARD SWITCH Push On/Push Off, Located on Top of Steering Column Cover		
: HEADLIGHT DIMMER SWITCH Integral with Turn Signal Lever		
: JUMP START STUD Located on Positive Terminal of Outermost Battery		
: PARKING LIGHT Integral with Front Turn Signal and Rear Tail Light		
: STARTER SWITCH Electric, Key Operated		
: STOP, TURN, TAIL & B/U LIGHTS Dual, Rear, Combination with Reflector		
: TURN SIGNAL SWITCH Self-Cancelling for Trucks, Manual Cancelling for Tractors, with Lane Change Feature		
: TURN SIGNALS, FRONT Includes Reflectors and Auxiliary Side Turn Signals, Solid State Flashers; Flush Mounted		
: WINDSHIELD WIPER SWITCH 2-Speed with Wash and Intermittent Feature (5 Pre-Set Delays), Integral with Turn Signal Lever		
: WINDSHIELD WIPERS Single Motor, Electric, Cowl Mounted		
: WIRING, CHASSIS Color Coded and Continuously Numbered		
CIGAR LIGHTER Includes Ash Cup	1/0	1
POWER SOURCE Cigar Type Receptacle without Plug and Cord	1/0	1
ALTERNATOR {Leece-Neville AV1160P2013} Brush Type; 12 Volt 160 Amp. Capacity, Pad Mount, With Remote Sense	0/0	0
BODY BUILDER WIRING Back of Standard Cab at Left Frame or Under Extended or Crew Cab at Left Frame; Includes Sealed Connectors for Tail/Amber Turn/Marker/ Backup/Accessory Power/Ground and Sealed Connector for Stop/Turn	2/0	2
BATTERY SYSTEM {International} Maintenance-Free, (2) 12-Volt 1850CCA Total	12/3	15

<u>Description</u>	<u>F/R Wt</u> (lbs)	<u>Tot Wt</u> (lbs)
RADIO AM/FM/WB/Clock/Bluetooth/USB Input/3MM Auxiliary Input, MP3, Apple Device Play & Control, Bluetooth for Phone & Music, with Multiple Speakers	1/0	1
HORN, ELECTRIC Disc Style	0/0	0
HORN, AIR Black, Single Trumpet, Air Solenoid Operated	2/0	2
HEADLIGHTS Halogen; Composite Aero Design for Two Light System; Includes Daytime Running Lights	0/0	0
CLEARANCE/MARKER LIGHTS (5) {Truck Lite} Amber LED Lights, Flush Mounted on Cab or Sunshade	0/0	0
TEST EXTERIOR LIGHTS Pre-Trip Inspection will Cycle all Exterior Lamps Except Back-up Lights	0/0	0
STARTING MOTOR {Delco Remy 38MT Type 300} 12 Volt; less Thermal Over-Crank Protection	0/0	0
INDICATOR, LOW COOLANT LEVEL With Audible Alarm	0/0	0
CIRCUIT BREAKERS Manual-Reset (Main Panel) SAE Type III With Trip Indicators, Replaces All Fuses Except For 5-Amp Fuses	0/0	0
TURN SIGNALS, FRONT LED, Includes LED Side Marker Lights, Mounted on Fender	0/0	0
GRILLE Chrome	0/0	0
FRONT END Tilting, Fiberglass, With Three Piece Construction	0/0	0
PAINT SCHEMATIC, PT-1 Single Color, Design 100	0/0	0
<u>Includes</u>		
: PAINT SCHEMATIC ID LETTERS "GA"		
PAINT TYPE Base Coat/Clear Coat, 1-2 Tone	0/0	0
SPECIAL RATING, GVWR Limited to 25,999-lb GVWR	0/0	0
CLUTCH Omit Item (Clutch & Control)	-68/-7	-75
ANTI-FREEZE Red, Extended Life Coolant; To -40 Degrees F/ -40 Degrees C, Freeze Protection	0/0	0
BLOCK HEATER, ENGINE 120 Volt/1000 Watt, for Cummins ISB/ISL Engines	3/0	3
ENGINE, DIESEL {Cummins ISB 300} EPA 2010, 300 HP @ 2600 RPM, 660 lb-ft Torque @ 1600 RPM, 2600 RPM Governed Speed, 300 Peak HP (Max)	0/0	0
FAN DRIVE {Borg-Warner SA85} Viscous Type, Screw On	0/0	0
<u>Includes</u>		
: FAN Nylon		
FEDERAL EMISSIONS {Cummins ISB} EPA, OBD and GHG Certified for Calendar Year 2016	0/0	0
RADIATOR Aluminum; 2-Row, Cross Flow, Over Under System, 717 SqIn Louvered, With 313 SqIn Charge Air Cooler. With In-Tank Transmission Cooler	34/-3	31
<u>Includes</u>		
: DEAERATION SYSTEM with Surge Tank		
: HOSE CLAMPS, RADIATOR HOSES Gates Shrink Band Type; Thermoplastic Coolant Hose Clamps		
: RADIATOR HOSES Premium, Rubber		
AIR CLEANER With Service Protection Element	0/0	0
<u>Includes</u>		
: GAUGE, AIR CLEANER RESTRICTION Air Cleaner Mounted		
THROTTLE, HAND CONTROL Engine Speed Control; Electronic, Stationary, Variable Speed; Mounted on Steering Wheel	0/0	0

<u>Description</u>	<u>F/R Wt</u>	<u>Tot Wt</u>
	(lbs)	(lbs)
ENGINE CONTROL, REMOTE MOUNTED - No Provision Furnished for Remote Mounted Engine Control	0/0	0
OIL PAN 15 Quart Capacity, For Cummins ISB Engines	0/0	0
EMISSION COMPLIANCE Federal, Does Not Comply With California Clean Air Idle Regulations	0/0	0
TRANSMISSION, AUTOMATIC {Allison 2500_RDS_P} 5th Generation Controls; Wide Ratio, 6-Speed, with Double Overdrive; with PTO Provision, Less Retarder, with 33,000-lb GVW & GCW Max	0/0	0
<u>Includes</u>		
: OIL FILTER, TRANSMISSION Mounted on Transmission		
: TRANSMISSION OIL PAN Magnet in Oil Pan		
TRANSMISSION OIL Synthetic; 20 thru 28 Pints	0/0	0
SHIFT CONTROL PARAMETERS Allison 1000 or 2000 Series Transmissions, 5th Generation Controls, with EcoCal and Dynamic Shift Sensing (FuelSense Basic)	0/0	0
AXLE, REAR, SINGLE {Navistar Select} Single Reduction, Hypoid Gearing, 19,000-lb Capacity, 190 Wheel Ends . Gear Ratio: 5.57	0/297	297
SUSPENSION, RR, SPRING, SINGLE Vari-Rate; 23,500-lb Capacity, With 4500 lb Auxiliary Rubber Spring	0/66	66
<u>Notes</u>		
: The following features should be considered when calculating Rear GAWR: Rear Axles; Rear Suspension; Brake System; Brakes, Rear Air Cam; Brake Shoes, Rear; Special Rating, GAWR; Wheels; Tires.		
FUEL/WATER SEPARATOR {Racor 400 Series,} Unheated, with Primer Pump, and WIF Sensor	7/2	9
LOCATION FUEL/WATER SEPARATOR Mounted Outside Left Rail 20" Back of Cab	0/0	0
FUEL TANK Top Draw; D-Style, Non-Polished Aluminum, 19" Deep, 70 U.S. Gal., 265 L Capacity, with Quick Connect Outlet, Mounted Left Side, Under Cab	14/1	15
<u>Notes</u>		
: N/A with 19.5" Tires		
DEF TANK 7 U.S. Gal. 26.5L Capacity, Frame Mounted Outside Left Rail, Under Cab	0/0	0
CAB Conventional	0/0	0
<u>Includes</u>		
: ARM REST (2) Molded Plastic; One Each Door		
: CLEARANCE/MARKER LIGHTS (5) Flush Mounted		
: COAT HOOK, CAB Located on Rear Wall, Centered Above Rear Window		
: CUP HOLDERS Two Cup Holders, Located in Lower Center of Instrument Panel		
: DOME LIGHT, CAB Rectangular, Door Activated and Push On-Off at Light Lens, Timed Theater Dimming, Integral to Console, Center Mounted		
: GLASS, ALL WINDOWS Tinted		
: GRAB HANDLE, CAB INTERIOR (1) "A" Pillar Mounted, Passenger Side		
: GRAB HANDLE, CAB INTERIOR (2) Front of "B" Pillar Mounted, One Each Side		
: INTERIOR SHEET METAL Upper Door (Above Window Ledge) Painted Exterior Color		
GUAGE CLUSTER English With English Electronic Speedometer	0/0	0
<u>Includes</u>		
: GAUGE CLUSTER (5) Engine Oil Pressure (Electronic), Water Temperature (Electronic), Fuel (Electronic), Tachometer (Electronic), Voltmeter		
: ODOMETER DISPLAY, Miles, Trip Miles, Engine Hours, Trip Hours, Fault Code Readout		
: WARNING SYSTEM Low Fuel, Low Oil Pressure, High Engine Coolant Temp, and Low Battery Voltage (Visual and Audible)		
GUAGE, OIL TEMP, AUTO TRANS , for Allison Transmission	1/0	1

<u>Description</u>	<u>F/R Wt</u>	<u>Tot Wt</u>
	(lbs)	(lbs)
IP CLUSTER DISPLAY On Board Diagnostics Display of Fault Codes in Gauge Cluster	0/0	0
GAUGE, DEF FLUID LEVEL	0/0	0
SEAT, DRIVER {National 2000} Air Suspension, High Back With Integral Headrest, Vinyl, Isolator, 1 Chamber Lumbar, With 2 Position Front Cushion Adjust, -3 to +14 Degree Angle Back Adjust	2/0	2
<u>Includes</u>		
: SEAT BELT 3-Point, Lap and Shoulder Belt Type		
SEAT, TWO-MAN PASSENGER {National} Vinyl, Less Under Seat Storage Compartment	41/19	60
MIRRORS (2) {Lang Mekra} Rectangular, Thermostatically Controlled Heated Heads, Bright Finish Heads, with Black Brackets and Arms, Breakaway Type, 7.55" x 14.1" Integral Convex Both Sides, 102" Inside Spacing,	-3/0	-3
CAB MOUNTING HEIGHT EFFECTS Mid Cab in Lieu of Low Cab Mounting Height (Approx. 4") With Cab Air Suspension	68/-4	64
ARM REST, RIGHT, DRIVER SEAT	3/0	3
AIR CONDITIONER {Blend-Air} With Integral Heater & Defroster	67/4	71
<u>Includes</u>		
: HEATER HOSES Premium		
: HOSE CLAMPS, HEATER HOSE Mubea Constant Tension Clamps		
: REFRIGERANT Hydrofluorocarbon HFC-134A		
INSTRUMENT PANEL Center Section, Flat Panel	0/0	0
WINDOW, POWER (2) and Power Door Locks, Left and Right Doors, Includes Express Down Feature	5/0	5
HVAC FRESH AIR FILTER	4/0	4
FRESH AIR FILTER Attached to Air Intake Cover on Cowl Tray in Front of Windshield Under Hood	1/0	1
CAB INTERIOR TRIM Premium	0/0	0
<u>Includes</u>		
: "A" PILLAR COVER Molded Plastic		
: CAB INTERIOR TRIM PANELS Cloth Covered Molded Plastic, Full Height; All Exposed Interior Sheet Metal is Covered Except for the Following: with a Two-Man Passenger Seat or with a Full Bench Seat the Back Panel is Completely Void of Covering		
: CAB SOUND INSULATION Includes Dash and Engine Cover Insulators		
: CONSOLE, OVERHEAD Molded Plastic; With Dual Storage Pockets with Retainer Nets, CB Radio Pocket, Speakers, and Reading Lights		
: COURTESY LIGHT (2) Mounted In Front Map Pocket Left and Right Side		
: DOOR TRIM PANELS with Cloth Insert on Bolster Driver and Passenger Doors		
: FLOOR COVERING Rubber, Black		
: GAUGE, TEMPERATURE, AMBIENT Includes Wiring and Sensor With Display Unit Mounted in Cluster		
: HEADLINER Soft Padded Cloth		
: INSTRUMENT PANEL TRIM Molded Plastic with Black Center Section		
: STORAGE POCKET, DOOR (2) Molded Plastic (Carpet Texture), Full-Length; Driver and Passenger Doors		
: SUN VISOR (3) Padded Vinyl: 2 Moveable (Front-to-Side) Primary Visors, Driver Side with Vanity Mirror and Toll Ticket Strap, plus 1 Auxiliary Visor (Front Only), Driver Side		
SUNSHADE, EXTERIOR Aerodynamic, Painted Roof Color; Includes Integral Clearance/Marker Lights	16/1	17
WHEELS, FRONT {Accuride} DISC; 22.5"x8.25" Rims, Painted Steel, 2-Hand Hole, 10-Stud, 285.75mm BC, Hub-Piloted, Flanged Nut, Metric Mount, with Steel Hubs	-10/0	-10
<u>Includes</u>		
: PAINT IDENTITY, FRONT WHEELS White		

Notes

**Description**

**F/R Wt** **Tot Wt**  
(lbs) (lbs)

: Compatible Tire Sizes: 11R22.5, 12R22.5, 255/70R22.5, 255/80R22.5, 265/75R22.5, 275/70R22.5, 275/80R22.5, 295/75R22.5, 295/80R22,5

WHEELS, REAR {Accuride} DUAL DISC; 22.5"x8.25" Rims, Painted Steel, 2-Hand Hole, 10-Stud, 285.75mm BC, Hub-Piloted, Flanged Nut, Metric Mount, with Steel Hubs

0/-20 -20

Includes

: PAINT IDENTITY, REAR WHEELS White

Notes

: Compatible Tire Sizes: 11R22.5, 12R22.5, 255/70R22.5, 255/80R22.5, 265/75R22.5, 275/70R22.5, 275/80R22.5, 295/75R22.5, 295/80R22,5

WHEEL SEALS, FRONT {International} Oil-Lubricated Wheel Bearings

0/0 0

BDY INTG, PTO ACCOMMODATION for (3) Latched Rocker Switches, (1) PTO Switch, (2) Generic Switches to Control (3) 30 amp relays, With Programmable Interlocks, for Body Builder Hook up in the Engine Compartment Left Side, Recommended for Automatic Transmissions

0/0 0

(4) TIRE, REAR 295/75R22.5 ECO PLUS HD3 (CONTINENTAL) 511 rev/mile, load range G, 14 ply

0/124 124

(2) TIRE, FRONT 295/75R22.5 ECO PLUS HS3 (CONTINENTAL) 519 rev/mile, load range G, 14 ply

60/0 60

**Services Section:**

WARRANTY Standard for Durastar 1000/4000 Series, Effective with Vehicles Built January 2, 2015 or Later, CTS-2475P

0/0 0

**Total Component Weight:**

**6384/4206 10590**

The weight calculations included in this proposal are an estimate of future vehicle weight. The actual weight as manufactured may be different from the estimated weight. Navistar, Inc. shall not be liable for any consequences resulting from any differences between the estimated weight of a vehicle and the actual weight.

<u>Description</u>	<u>(US DOLLAR)</u>	<u>Price</u>
Total Factory List Price Including Options:		\$99,112.00
Dealer Prep & Service	\$375.00	
Safety Equipment Installed in Cab	\$110.00	
Total Preparation And Delivery:		\$485.00
Freight	\$2,375.00	
Total Freight:		\$2,375.00
Total Factory List Price Including Freight:		\$101,972.00
Less Customer Allowance:		(\$29,972.00)
Total Vehicle Price:		\$72,000.00
Total Sale Price:		\$72,000.00
Total Per Vehicle Sales Price:		\$72,000.00
Net Sales Price:		\$72,000.00

Please feel free to contact me regarding these specifications should your interests or needs change. I am confident you will be pleased with the quality and service of an International vehicle.

**Approved by Seller:**

**Accepted by Purchaser:**

\_\_\_\_\_  
**Official Title and Date**

\_\_\_\_\_  
**Firm or Business Name**

\_\_\_\_\_  
**Authorized Signature**

\_\_\_\_\_  
**Authorized Signature and Date**

HICKORY INTERNATIONAL INC  
1704 CONOWINGO RD  
P.O. BOX 469  
BEL AIR MD 21014 -  
(410)838-4200

**This proposal is not binding upon the seller without Seller's Authorized Signature**

\_\_\_\_\_  
**Official Title and Date**

**The TOPS FET calculation is an estimate for reference purposes only. The seller or retailer is responsible for calculating and reporting/paying appropriate FET to the IRS.**